

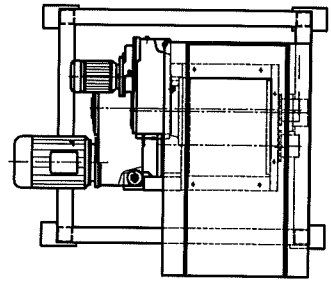

## Instruktionsbok för MOCO Kvarn - Shredder

### Specifikationer

Modell:	AZ09F
Order nr:	AL 21496
Maskin nr:	7922
Tillverkningsår:	2012
Leveransdatum:	Maj 2012
Vikt:	1495 kg
Motor och Drivning:	P = 11 kW n1 = 1465 rpm n2 = 47 rpm
Knivar:	19mm, 4 hook
Knivmontage:	Singelmontage med avrivare
Matarspänning:	400 / 690V - 50 Hz
Strömstyrka:	20,6 / 11,9 A
Byggnadsform:	M6
Skyddsutförande:	IP 55
Maskin nr:	7318 AL20268/1
Reservdelslista:	Maskinspecifik
Extra utrustning:	Nerdragare typ ZB 1

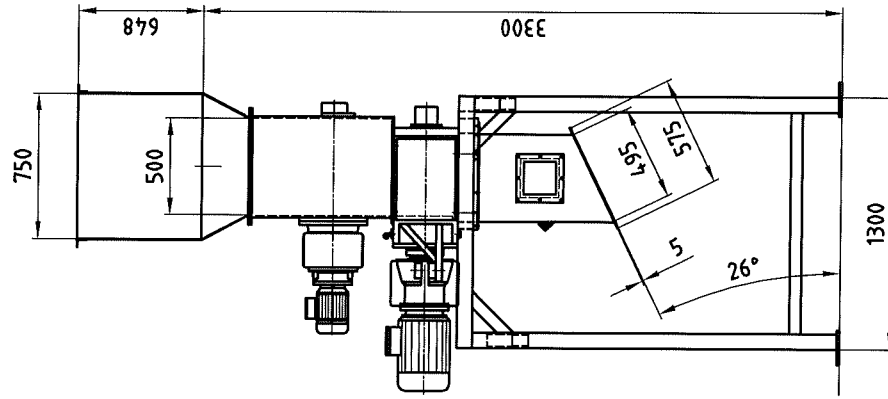
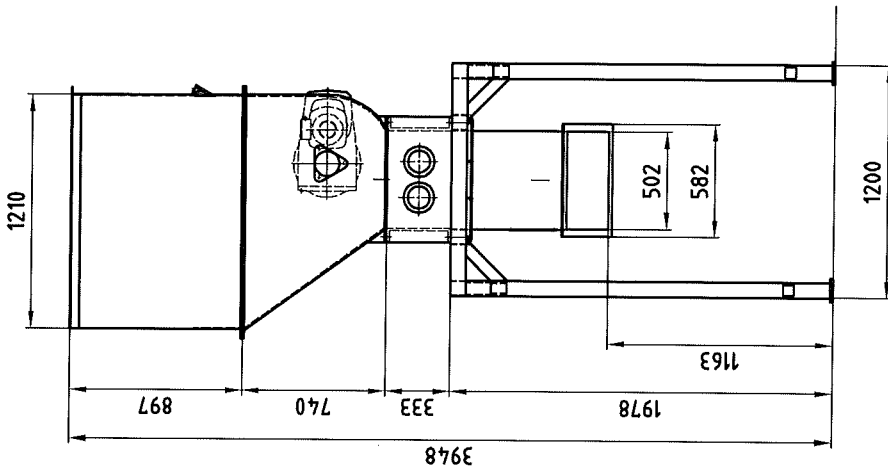

Verwendungsbereich <b>AZ 9F</b>		Zul. Abweichung DIN 7168 mittel	Oberfläche	Maßstab 1:25	Gewicht
Zust.		Überarbeitet	29.02.12	Verstärkt, Halbhang Bohrloch- Modell- oder Geometrie-Nr.	<b>AZ 9F + ZB 1</b>
Änderungen		Datum	Norm	Bezeichnung	
Das Urheberrecht an dieser Zeichnung gehört uns. Diese Zeichnung darf ohne unsere schriftliche Genehmigung weder kopiert noch driften. Jeder Nachdruck wird strafrechtlich verfolgt.		00EE	ISO Normen- & Apparaten Qualität (DIN) Normen	Zeichnungsnummer	<b>AL 214 96</b>
Ungers		Ers. fr.	Index 1	Ers. di	<b>8</b>



<b>Order :</b> AL 21496	<b>AZ 9 F Kvarn / Shredder</b> <b>Kniv konfiguration</b> <b>Cutter arrangement</b>	<b>MOCO</b> Maschinen-u. Apparatebau GmbH & Co.KG 68519 Viernheim
<b>Date :</b> 01.02.12 Mu.		

<b>Längd skärkammare : 392 mm</b> <b>Bredd skärkammare : 500 mm</b> <b>Singel monterade knivar 19 mm</b> <b>2 slitplattor 20 mm</b>	<b>Lenght cutting chamber : 392 mm</b> <b>Width cutting chambe : 500 mm</b> <b>Singel cutter 19 mm</b> <b>2 wearing plates 20 mm</b>
--	---

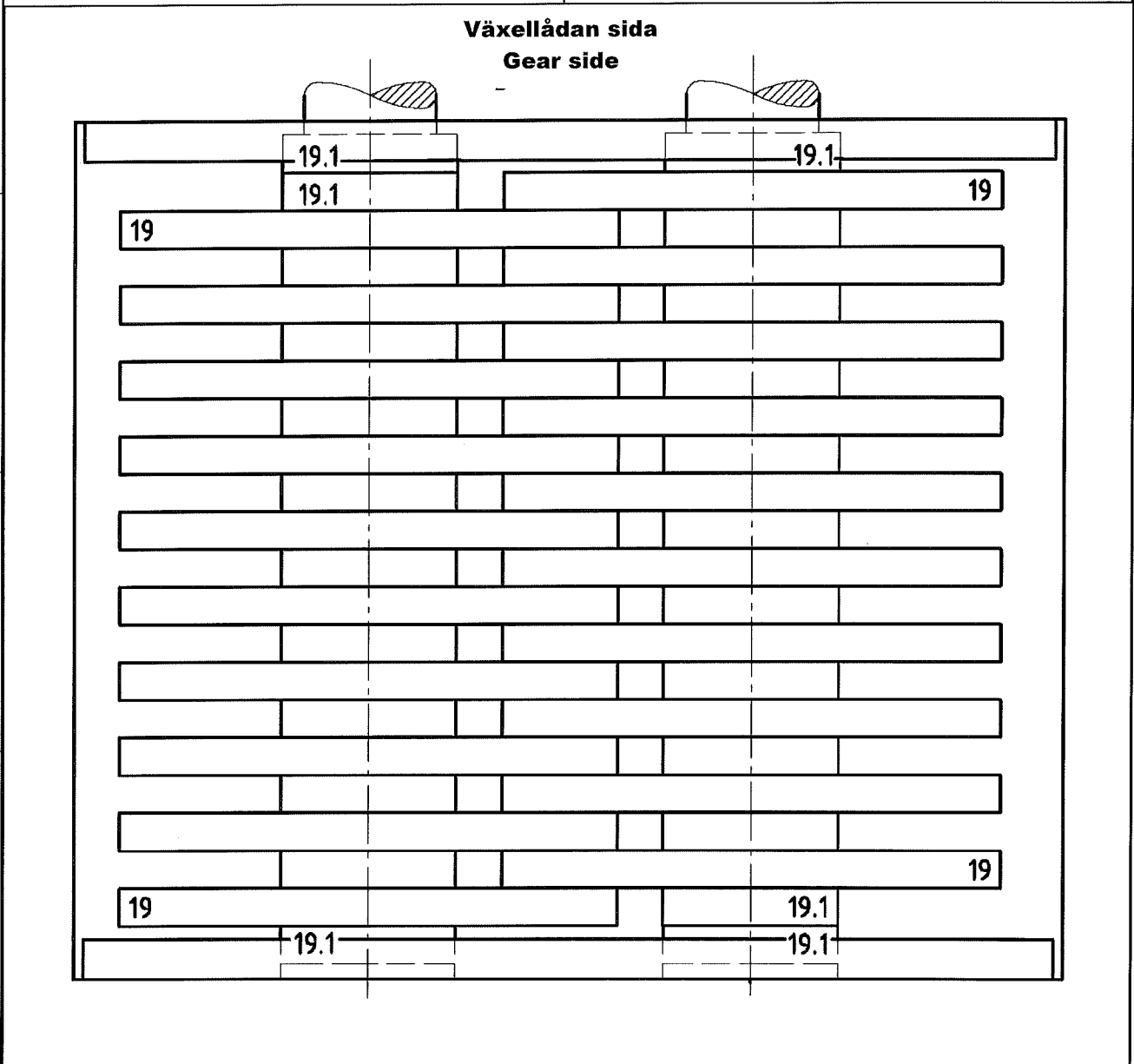

	Drg. No.	Quant.	Drg. No.	Quant.	Drg. No.	Quant.	Drg. No.	Quant.
<b>Kniv / Cutter</b>	822-3	20						
<b>Distansring / Collar</b>	AL 21496 A	20	AL 21496 B	4				
<b>Avrivare / Rakes</b>	AL 21496 C	20						